

MEET

KIPP™



MOST SECURE.
SIMPLEST SERVICEABILITY.
BEST USER EXPERIENCE.

OUR STANDARD AND MOST VERSATILE BTM SOLUTION.

Built with security in mind, KIPP's quality components provide an unmatched user experience. Operators will enjoy simple serviceability, with service times on all components clocking in at under two minutes. The sleek, polished look of this unit is the perfect foundation to make your brand stand out in any retail space.

American Kiosks can offer a number of ready-to-go products which can help lower costs and reduce lead-times. We are committed to providing the highest quality products, services, and experiences for your current projects and future visions. We offer competitive timelines, capability for customization, and exceptional payment terms.



User Identity Camera

User-friendly touchscreen

Dynamic LEDs and indicator lights

Flexible cash options - accept or recycle

Your brand's look and feel

KEYS TO OPERATIONAL SUCCESS >>



USER EXPERIENCE

Easy to use pinpad, ADA accessibility device, clear screen and LEDs



VERSATILITY

Equipped with cash in and out capabilities, options for cash recycler



SECURITY

1/4" steel cash vault and options for security shield of 1/4" steel

Talk to our team today at sales@americankiosks.com to learn more about KIPP, or visit www.americankiosks.com for a look at all our products.



KIPP (KI-1000)

Improve customer satisfaction through secure, efficient transactions.

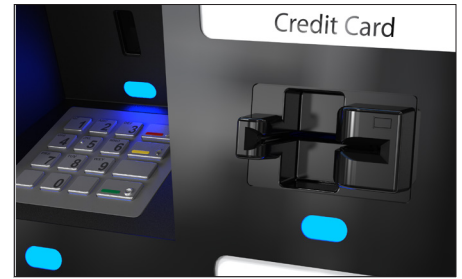

SPECIFICATIONS >>

Dimensions

22.3" Depth

18.3" Width

62.6" Height

350lbs Weight

Components

User Identity Camera

21.5" PCAP Touchscreen Display

Cellular Capability

Bar Code Scanner

Thermal Receipt Printer

Insert Credit Card Reader

1/4" Steel Security Shield Options

User-Friendly Pinpad

2,200 Note Bill Acceptor

1/4" Steel Internal Vault

1,500 Note Bill Dispenser

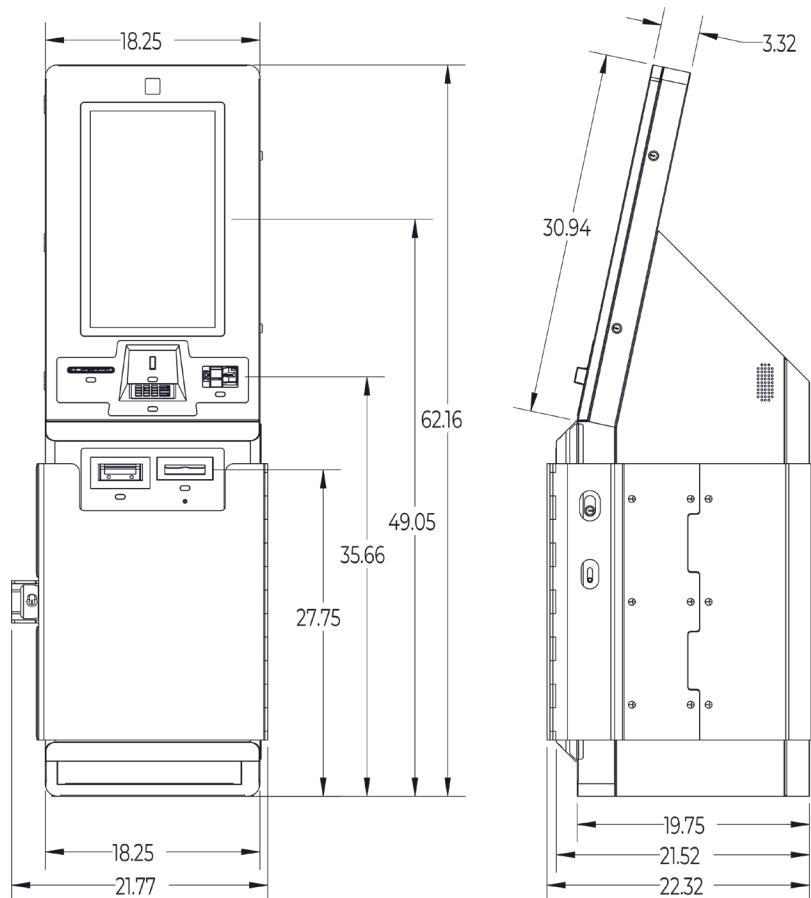

KIPP is a flexible and robust unit that turns heads in the self-service kiosk market. With hundreds of component combinations and the ability to be involved in the design process, our engineering team will work with you to create the solution that is right for you.



www.americankiosks.com

(720) 882-0748

sales@americankiosks.com

Made in the USA