

MEET TARA™

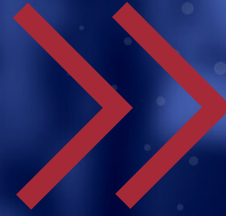

USER FOCUSED.
SMALL FOOTPRINT.
SMOOTHER CHECK-INS.

RELIEVE HIRING PAINS & REFOCUS YOUR STAFF.

TARA is the agile countertop kiosk that can eliminate errors and improve all steps of the check-in process. Guests check in using simple instructions, avoid long lines at the front desk, and get their room key with less hassle. The simple touchscreen interface allows them to breeze through check-in and key card distribution. TARA can be used in a range of hospitality applications.

American Kiosks offers ready-to-go products which can help lower costs and reduce lead-times. We are committed to providing quality products and services for your current projects and future visions. We offer competitive timelines, capability for customization, and exceptional payment terms.

KEYS TO OPERATIONAL SUCCESS >>



EASE OF USE

Clear instructions and LEDs guide users through self check-in



FUNCTIONALITY

Guests can check in, change reservations, pay, and reserve amenities



SERVICEABILITY

Highest quality, easily serviceable parts when every minute matters



POWERED BY:

meldcx™  chrome OS

Talk to our team today at sales@americankiosks.com to learn more about TARA, or visit www.americankiosks.com for a look at all our products.



TARA (TR-1000)

Improve customer satisfaction through secure, efficient transactions.



SPECIFICATIONS >>

Components

- Chrome OS
- Room Key Dispenser
- Passport Reader
- User Identity Camera
- Card Payment
- Microphone & Speaker
- 21.5" Touchscreen Display
- Bar Code Scanner
- STORM Assistive Interface
- Pinpad (ADA)

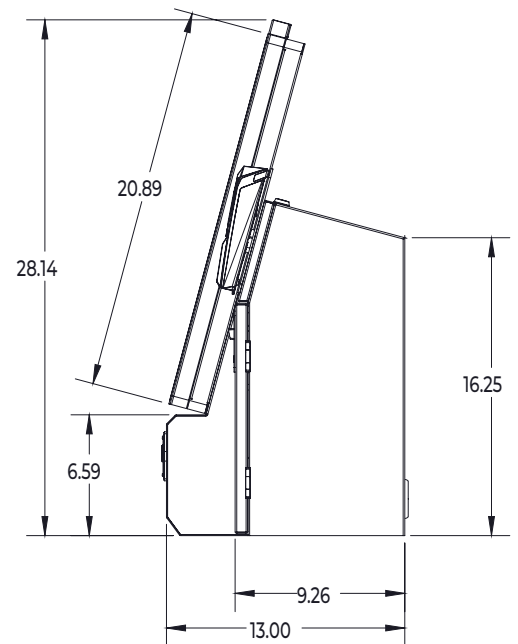
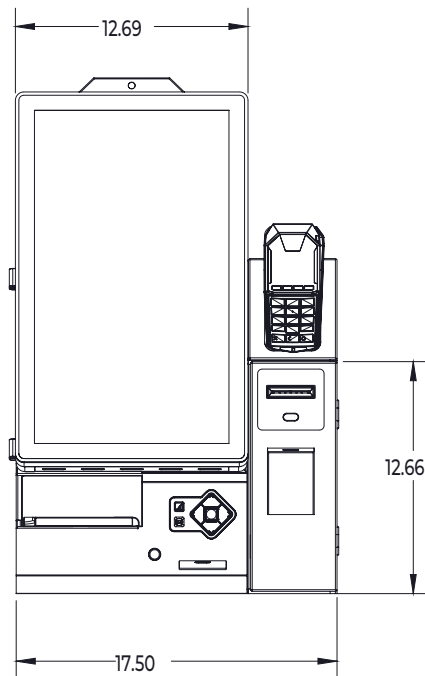

Dimensions

- 11.75" Depth 26.75" Height
- 11.75" Width 35lbs Weight

TARA is a flexible and robust unit that turns heads in the self-service kiosk market. With hundreds of component combinations and the ability to be involved in the design process, our engineering team will work with you to create the solution that is right for you.

